

# Assistive Tech Solutions

www.atsolutions.org

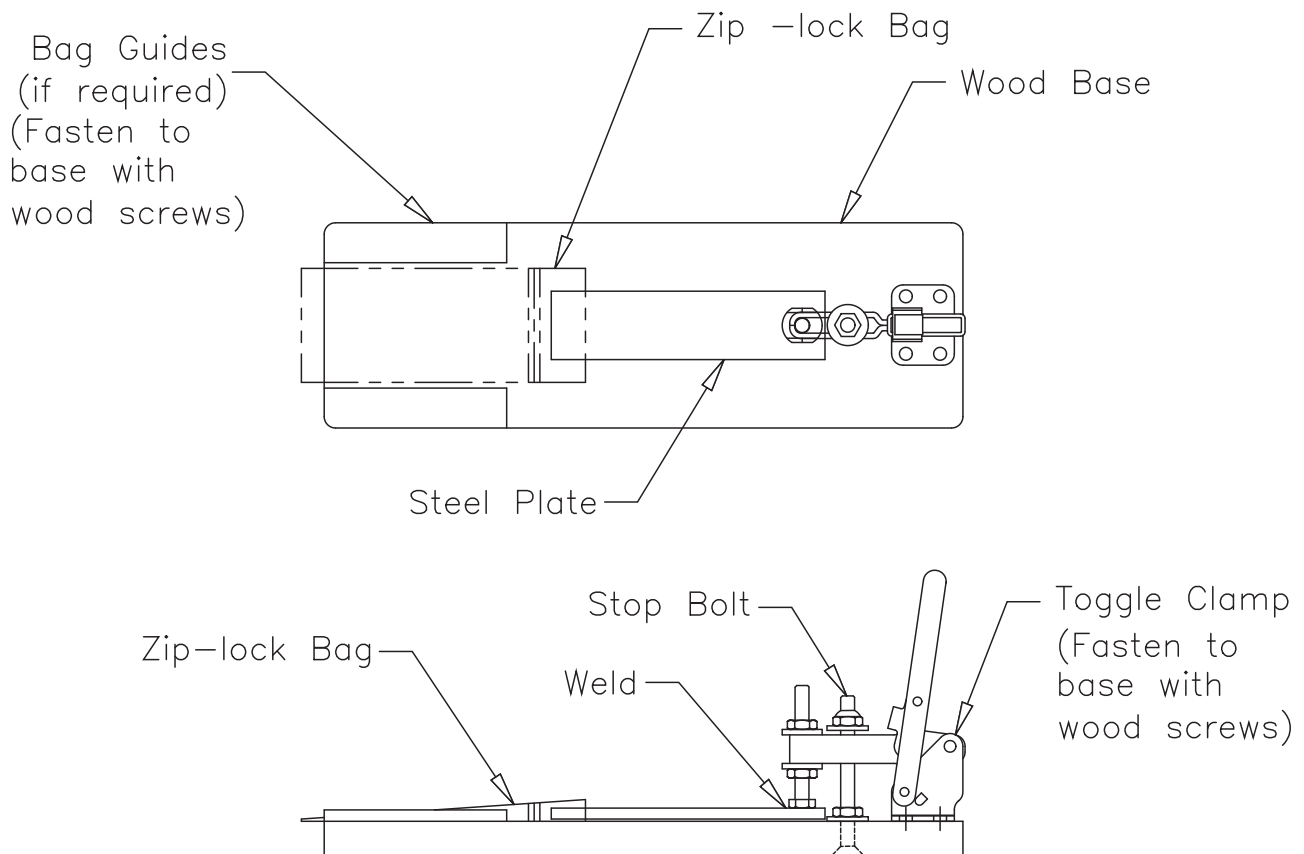

## Material List:

- 1 - 3/4" plywood base about twice as long and 2" wider than bag
- 1 - 10 ga x 1 1/2" wide steel plate and about 2" longer than bag contents
- 2 - 5/16 x 3 1/2 flat head cap screw with 2 washers and lock nut and hex nut
- 2 - Wood bag guides, 1" wide and about same length as bag
- 8 - 3/4" wood screws
- 1 - Toggle clamp \*
- 1 - Steel spindle assembly \*

\* Toggle clamp shown:

CL-450-VTC Clamp with CL-516212-SA Spindle

Available from:

Carr Lane Manufacturing Company  
4200 Carr Lane Ct.  
P.O. Box 13149  
St. Louis, MO 63119  
314-647-6200